

Introduction

This application note describes how to make a PWM LED dimming circuit incorporating feedback control in GreenPAK. This circuit is implemented in one of the smallest GreenPAK's, the SLG46120V, and thus is easily portable to other GreenPAK's.

External Circuit

As shown in Figure 1, there are 2 analog voltages; one is made by R1 and VR (0V...VDD/3) which is fed to PIN4 and PIN6. Another is made by R2 and C1, which converts the LED PWM duty (0%...100%) to analog voltage (0V...VDD), and goes to PIN3 which is configured to divide by 3 by internal gain control. The 2 analog voltages are compared to each other by internal comparator ACMP0 (see Figure 2). If PIN4 voltage is higher than PIN3, the PWM duty need to be increased; otherwise PWM duty need to be decreased. This comprises the analog feedback path that provides the desired regulation.

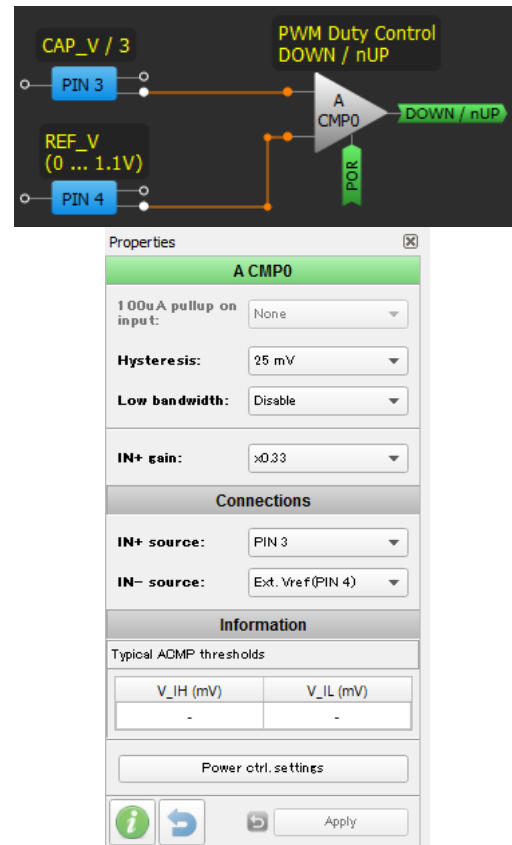

Figure 2. ACMP0 Settings

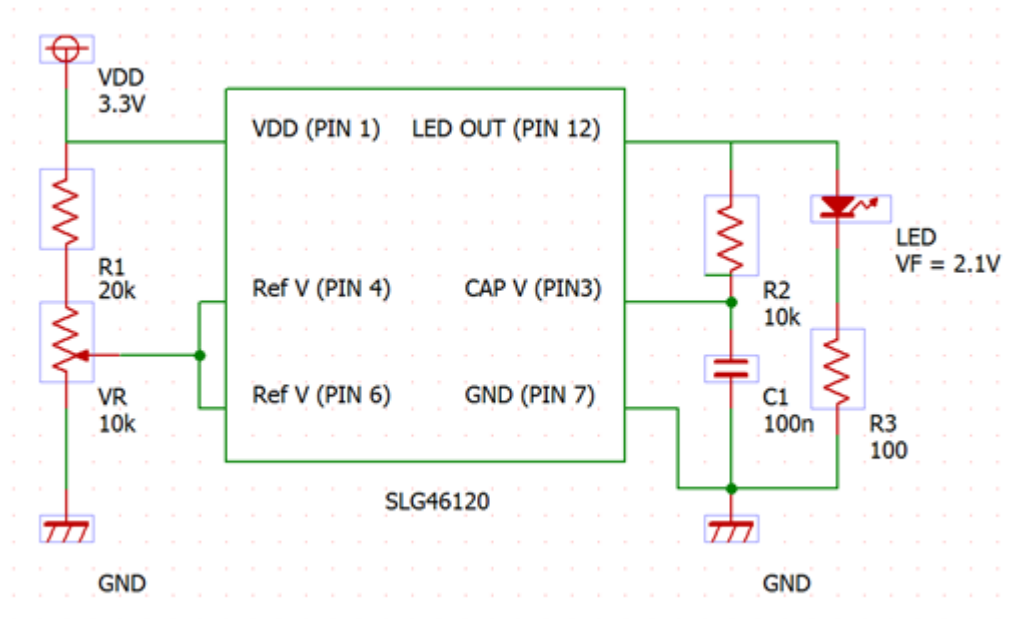

Figure 1. External Circuit



GreenPAK Design, PWM Control

Figure 3 shows the main part of the PWM circuit which is the same as the one described in AN-1117. CNT2 makes a "reset" pulse every 0.1ms and CNT3 makes a "set" pulse every 0.1ms. LUT6 latches the "set" and "reset" signals and makes the PWM waveform (see Figure 4).

Both of CNT2 and CNT3 counter data are set to 199, so the resolution of this PWM is 200 steps and its period is 0.1ms. Please note that these two counter values must be equal to keep the PWM consistent.

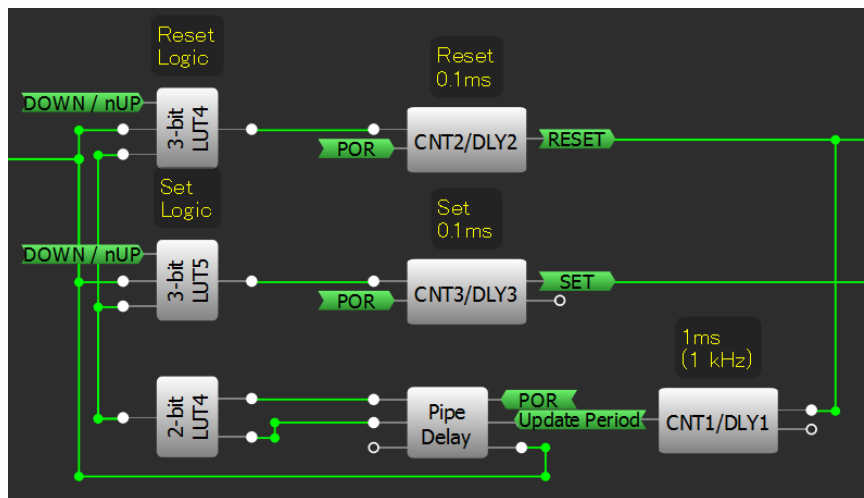

Figure 3. PWM Circuit

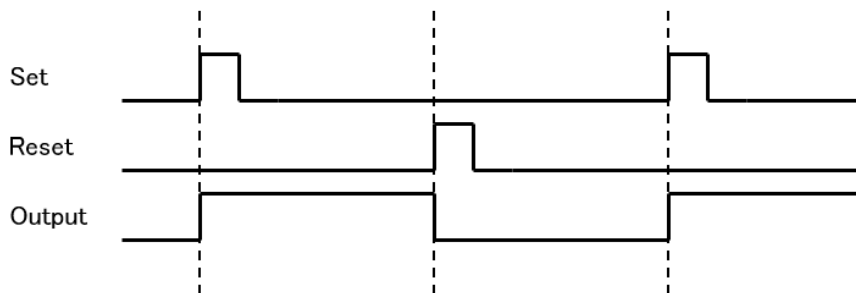
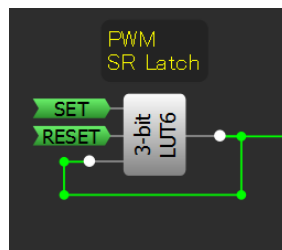

Figure 4. PWM SR Latch

Properties

3-bit LUT6

IN3	IN2	IN1	IN0	OUT
0	0	0	0	0
0	0	0	1	1
0	0	1	0	0
0	0	1	1	0
0	1	0	0	1
0	1	0	1	1
0	1	1	0	0
0	1	1	1	0
1	0	0	0	0
1	0	0	1	0
1	0	1	0	0
1	0	1	1	0
1	1	0	0	0
1	1	0	1	0
1	1	1	0	0
1	1	1	1	0

Standard gates: Defined by user

Regular shape

All to 0, All to 1, Invert, Apply



3-bit LUT4 Truth Table:

IN3	IN2	IN1	IN0	OUT
0	0	0	0	0
0	0	0	1	0
0	0	1	0	1
0	0	1	1	1
0	1	0	0	0
0	1	0	1	1
0	1	1	0	1
0	1	1	1	0
1	0	0	0	0
1	0	0	1	0
1	0	1	0	0
1	0	1	1	0
1	1	0	0	0
1	1	0	1	0
1	1	1	0	0
1	1	1	1	0

3-bit LUT5 Truth Table:

IN3	IN2	IN1	IN0	OUT
0	0	0	0	0
0	0	0	1	1
0	0	1	0	1
0	0	1	1	0
0	1	0	0	0
0	1	0	1	0
0	1	1	0	1
0	1	1	1	1
1	0	0	0	0
1	0	0	1	0
1	0	1	0	0
1	0	1	1	0
1	1	0	0	0
1	1	0	1	0
1	1	1	0	0
1	1	1	1	0

Figure 5. LUT4, LUT5 Settings

At every CNT1 period (1ms), either CNT2 or CNT3 gets one extra clock by 3-bit LUT4 or LUT5, respectively (see Figure 5). Thus PWM duty is 1 step increased or decreased depending on the "DOWN/nUP" signal every 1ms. By increasing CNT1 value, we can slow down the LED brightness ramp rate, and thus get more "smoothing" effect.

PWM Overflow Prevention

In order to avoid overflow or underflow of PWM cycle, there are two additional circuits.

For underflow control, ACMP1 is used with 50mV internal reference (see Figure 6). When REF_V is lower than 50mV "nForce 0%" signal is activated (active low) and forces PWM duty to 0%.

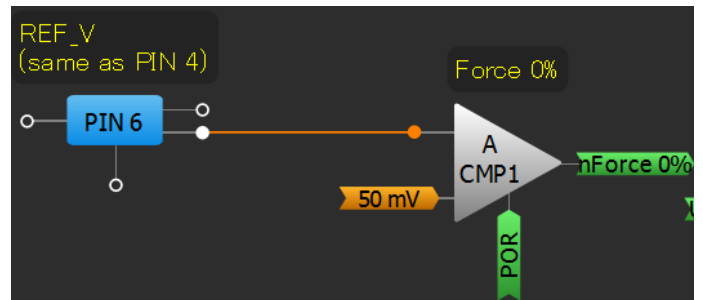

Figure 6. Underflow Control

Figure 7 illustrates overflow control.

When "set" and "reset" pulses are overlapped completely and "DOWN/nUP" signal is "nUP", "Force 100%" signal is activated (active high) and PWM duty is forced to 100%.

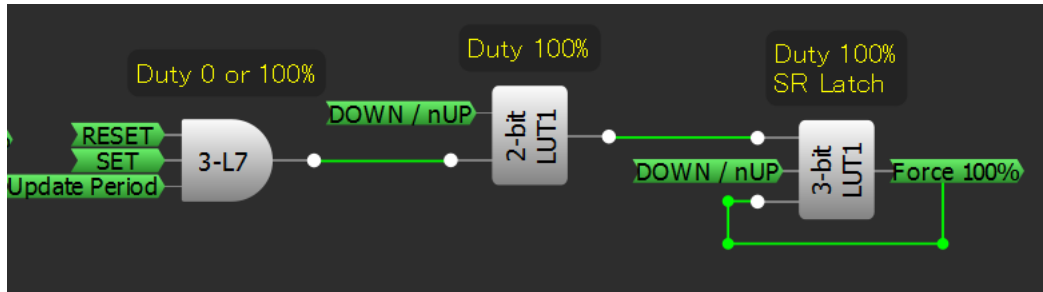

Figure 7. Overflow Control

As a result, a relationship between "REF_V" and "PWM Duty" is as follows;

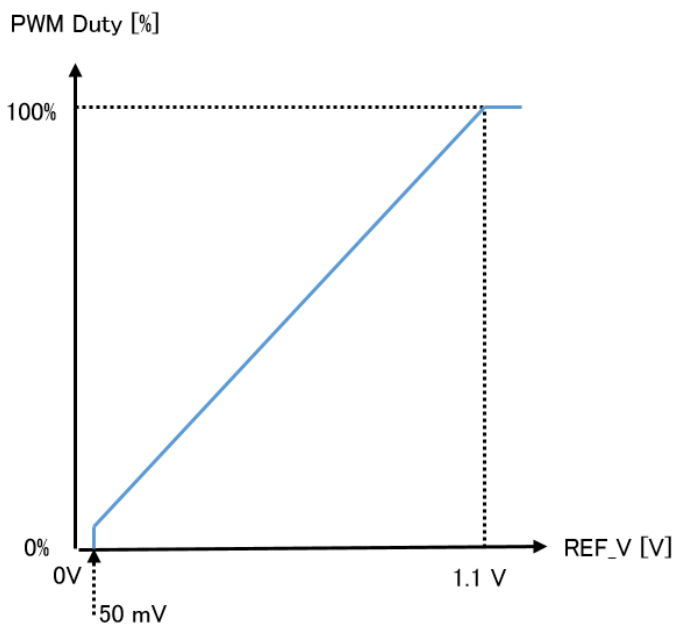

Figure 8. REF_V vs. PWM Duty

In order to make smooth transitions to/from "Force 0%/100%" and normal operation, OSC output is gated when this "Forced" situation happens so that both of CNT2 and CNT3 keep last counter value (see Figure 9)

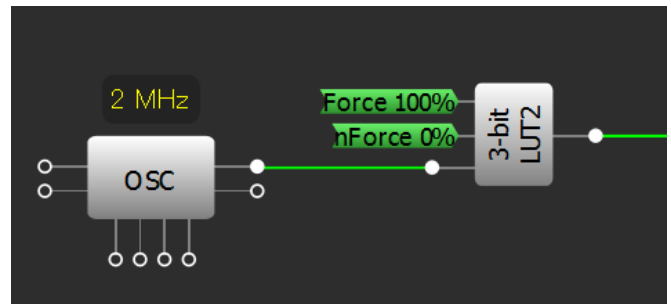

Figure 9. Clock control when PWM duty is 0 or 100%

Functionality Waveforms

Figure 10 shows actual PWM waveform with internal "set" and "reset" signals.

- Channel 1 (yellow) – "RESET"
- Channel 2 (light blue) – "SET"
- Channel 3 (magenta) – LED OUT (PIN 12)
- Channel 4 (blue) – REF_V (PIN 4 and 6)

A movie file, "LED_Dimmer.mov" is available; it shows how "REF_V" signal controls "SET", "RESET" signals and PWM output.

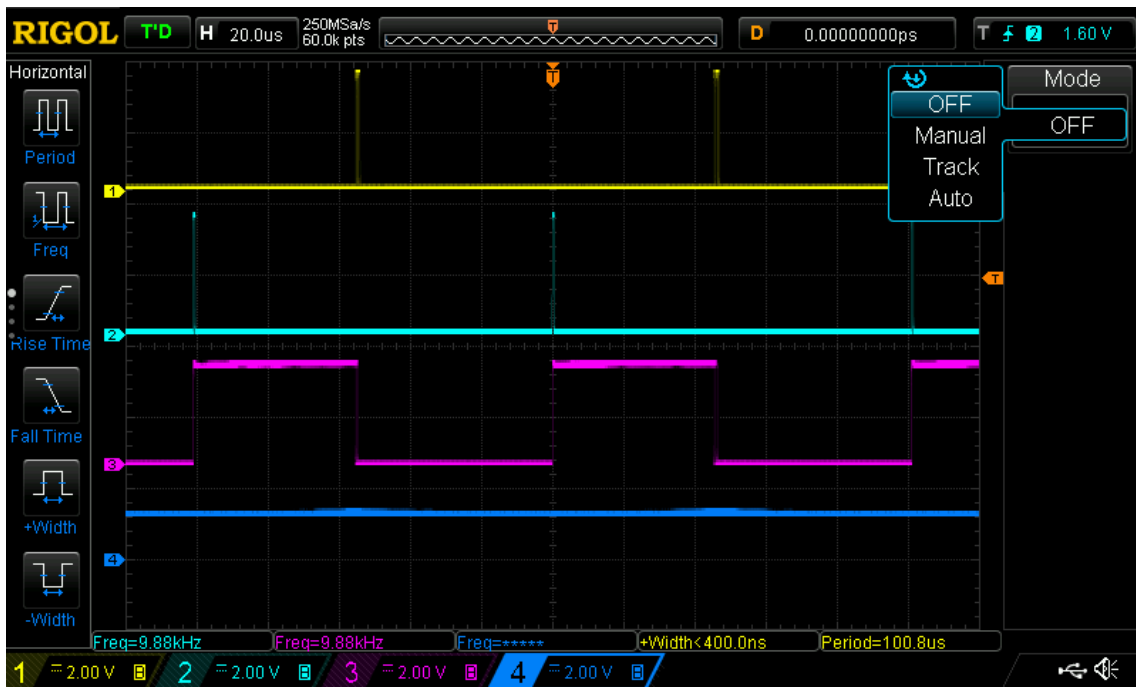

Figure 10. PWM waveform

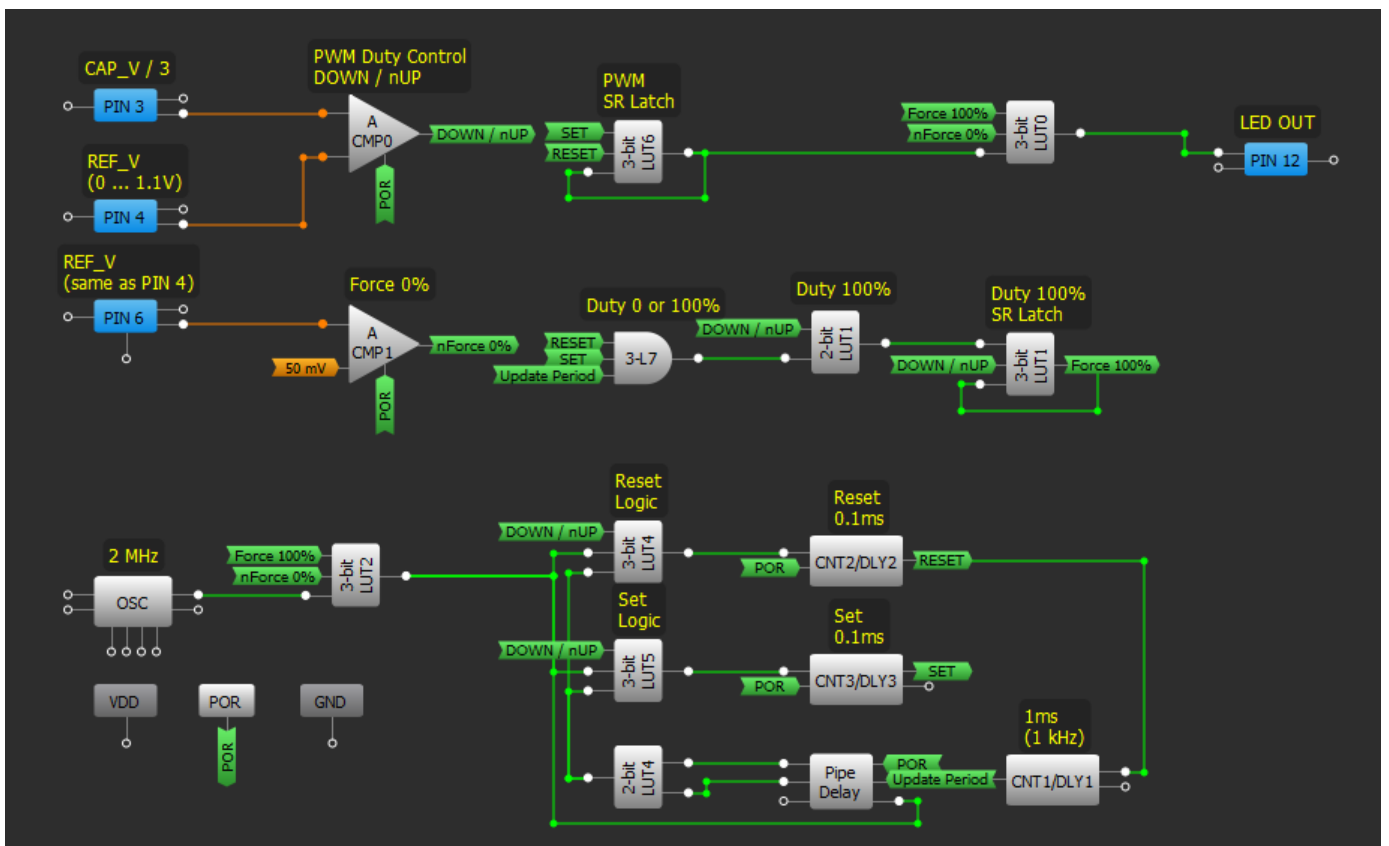

Figure 11. Entire Circuit



Conclusion

This LED dimmer circuit example shows how to create a PWM circuit with feedback control, making use of both analog and digital elements. With GreenPAK's flexible analog and digital components, such circuits can be easily implemented.



About the Author

Name: Shimpei Saito

Background: Shimpei is working at Silego Technology Japan as a Senior Field Application Engineer.

Contact: [**appnotes@silego.com**](mailto:appnotes@silego.com)



Document History

Document Title: LED Dimmer with Analog Regulation

Document Number: AN-1122

Revision	Orig. of Change	Submission Date	Description of Change
A	Shimpei Saito	09/20/2016	New application note

Worldwide Sales and Design Support

Silego Technology maintains a worldwide network of offices, solution centers, manufacturer’s representatives, and distributors. To find the sales person closest to you, visit us at **Sales Representatives and Distributors.**

About Silego Technology

Silego Technology, Inc. is a fabless semiconductor company headquartered in Santa Clara, California, with operations in Taiwan, and additional design/technology centers in China, Korea and Ukraine.

