

## Introduction

The aim of this app note is to create a parking assistant device using a Silego GreenPAK configurable Mixed-Signal IC and the **SHARP GP2Y0A60SZLF** distance measuring sensor.

Many modern vehicles come with this feature, but the techniques described in this app note will allow anyone to create their own removable parking assistant device.

## Theory behind sensing

The GP2Y0A60SZLF sensor is a distance-measuring component with an operational range between 10-150 cm. It includes a signal processing circuit and has a small size of 22 x 8.0 x 7.2mm. Its analog output makes it a great fit for the GreenPAK to work with.

This sensor works by measuring the light reflected off of the surface of an object to determine the object's distance from our sensor. Neither temperature, variation of the reflectivity of the object, nor duration of the reading influence the measurements.

The GP2Y0A60SZLF can be purchased in a **module** with the necessary circuit components included, as shown in Figure 1. If the user purchases the sensor separately, they will need to include the circuitry shown in Figure 2.



**Figure 1. GP2Y0A60SZLF Analog Distance Sensor**

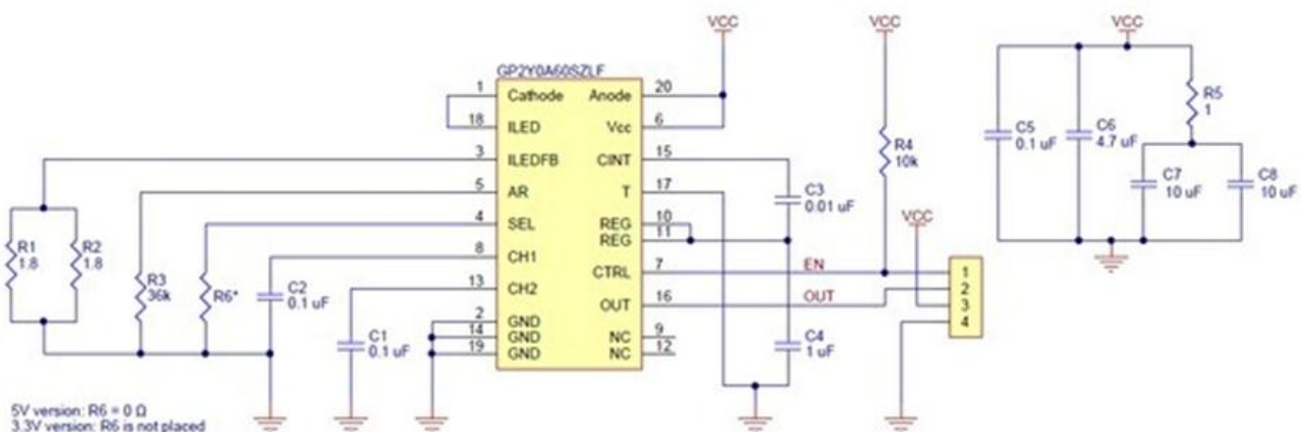

**Figure 2. Sensor circuitry**



The GP2Y0A60SZLF datasheet provides the graph shown in figure 3, depicting the voltages given as an output of the sensor in presence of a white sheet of paper.

**Addressing different materials**

Since every material has different reflection characteristics, the versatility of this sensor becomes a concern and needs verification.

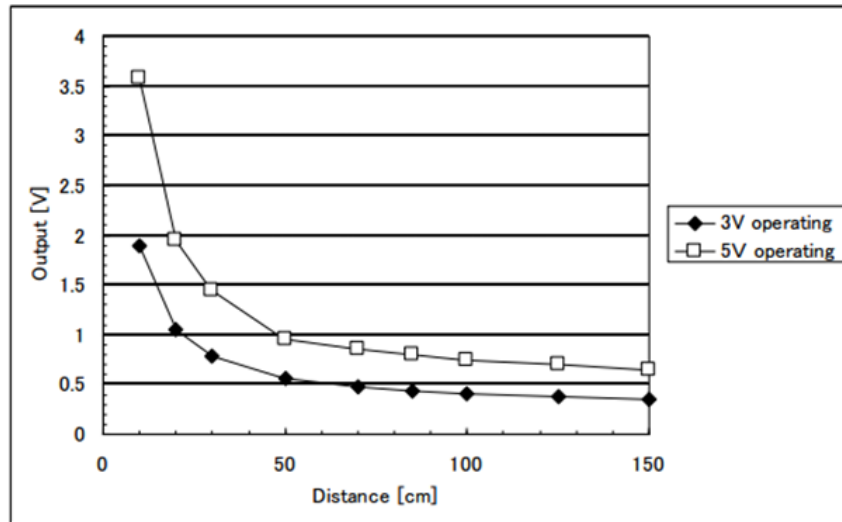

**Figure 3. Output voltage graph**

Concrete Green		Wood		Plastic (Black)		Cloth (Jeans)		Car (white)	
Distance	Voltage	Distance	Voltage	Distance	Voltage	Distance	Voltage	Distance	Voltage
5	4.25	5	4.25	5	4.18	5	4.2	5	4.27
10	3.45	10	3.29	10	3.07	10	3.36	10	3.39
20	1.85	20	2.27	20	2.04	20	2.18	20	1.98
30	1.42	30	1.77	30	1.63	30	1.6	30	1.53
40	1.17	40	1.44	40	1.36	40	1.28	40	1.26
50	1.05	50	1.3	50	1.2	50	1.14	50	1.18
60	0.97	60	1.17	60	1.08	60	1.03	60	1.06
70	0.91	70	1.04	70	1.03	70	0.98	70	0.98
80	0.88	80	0.96	80	0.98	80	0.93	80	0.91
90	0.85	90	0.92	90	0.9	90	0.89	90	0.86
100	0.8	100	0.86	100	0.82	100	0.86	100	0.79

**Figure 4. Comparative table of voltage from different materials**



Cars come in different shapes, sizes, and colors, so we charted the sensor's behavior in front of different materials to make sure it is compatible with as many materials as possible. Figure 4 table shows our results, which are displayed as a graph in Figure 5.

### Developing the GreenPAK file

To start testing the device we will stick to the output voltages given in the datasheet (Figure 3). Fortunately, the values remain similar according to distance regardless of which material.

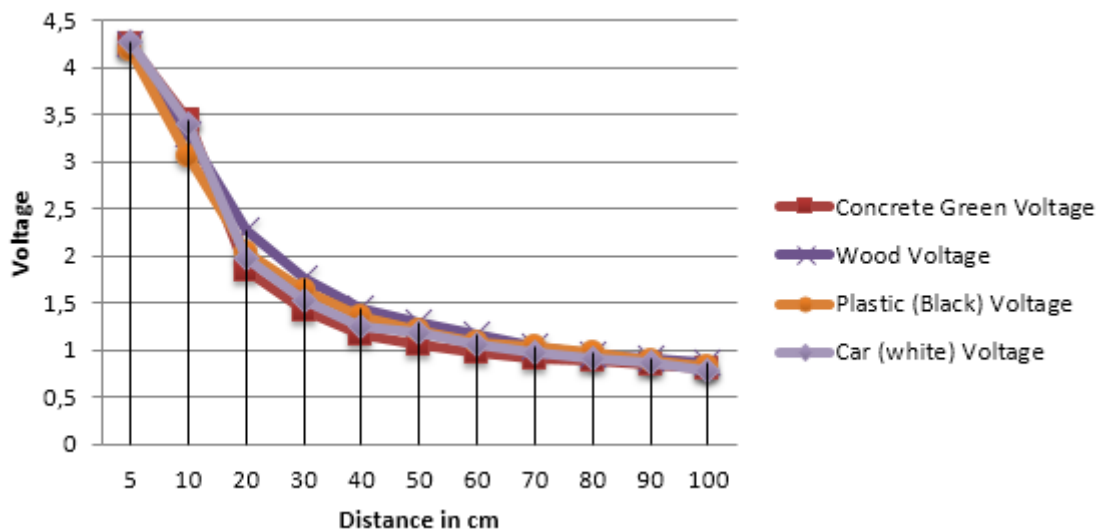

**Figure 5. Voltage graph**

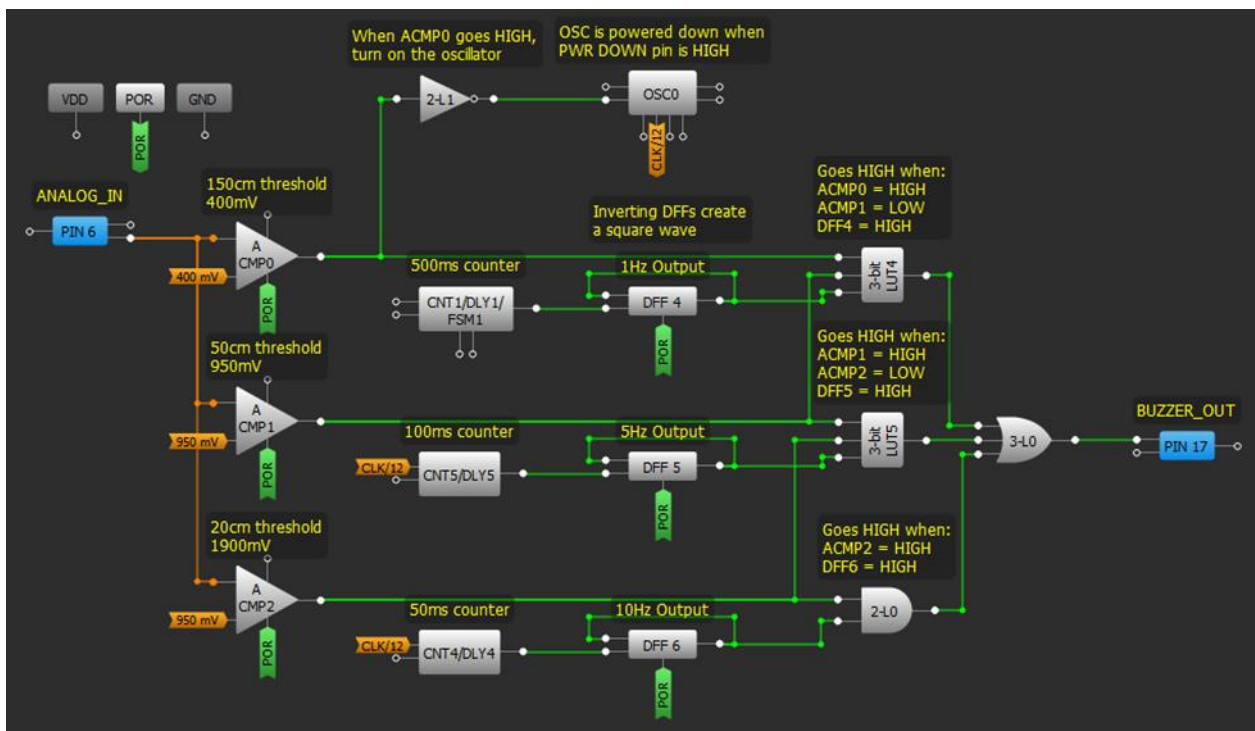

**Figure 6. GreenPAK Designer circuit**



For now, we will select the following distances:

- 20 cm should give us an output voltage of 1.9 V
- 50 cm should give us an output voltage of 0.95 V
- 150 cm should give us an output voltage of 0.50 V

All of the values used in the .gp file were chosen from the Datasheet. Nevertheless, the practical characterization of the sensor using other materials tells us that there is no real significant difference in the voltage of the readings. Therefore it is possible to use the graph in the datasheet to apply this app note concept to get a good general distance sensor. If needed, it can be adjusted to work with a certain material under certain conditions.

The alarm will go off under the following conditions:

- 150cm distance will make a beeping sound with a frequency of 1 Hz
- 50cm distance will make a beeping sound with a frequency of 5 Hz
- 20cm distance will make a beeping sound with a frequency of 10 Hz

Pin 6 in the GreenPAK design is connected to all 3 of the analog comparators as shown in Figure 6. Thanks to the ACMP gain options, the user can select threshold values from 50mV to 4.8V.

To create the 3 different buzzer frequencies, we used one counter and one inverting D-flip flop per buzzer. For instance, CNT1 outputs a pulse every 500ms. Those pulses clock inverting DFF4, which creates a 1Hz square wave. The same technique was used to create a 5Hz and 10Hz square wave.

Figure 7 illustrates the functionality of the design.

Channel 1: Pin 6 (ANALOG\_IN)

Channel 2: Pin 17 (BUZZER\_OUT)

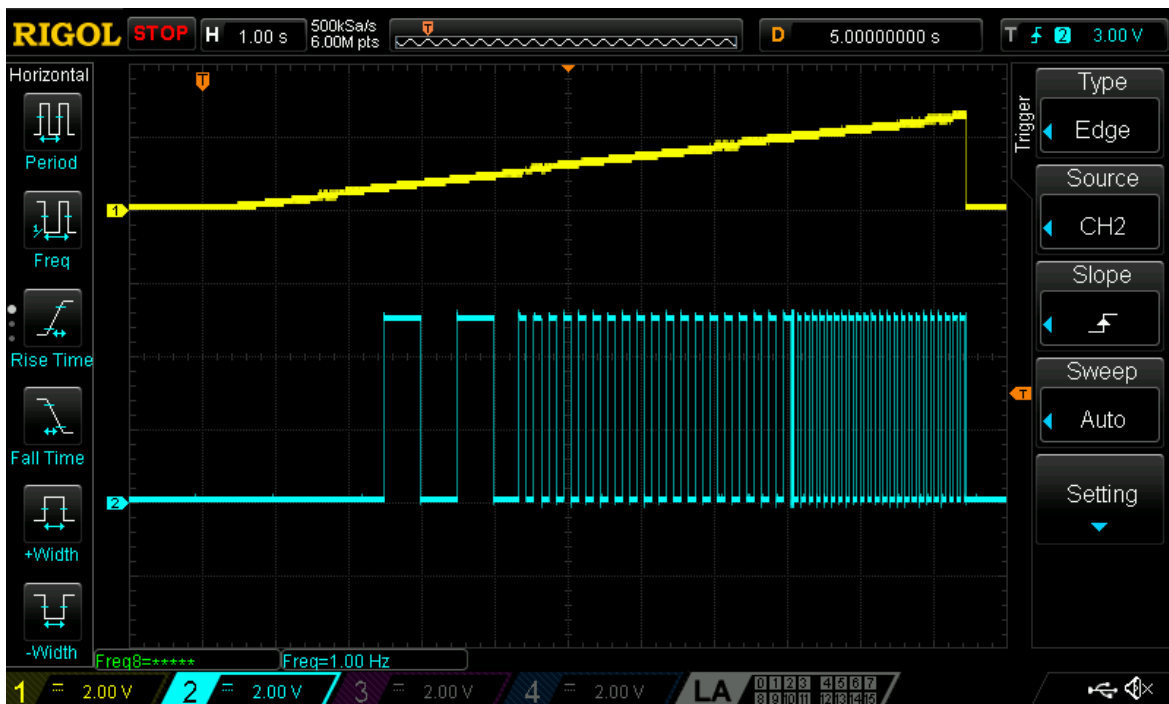

**Figure 7. PIN6 and PIN17 waveforms**

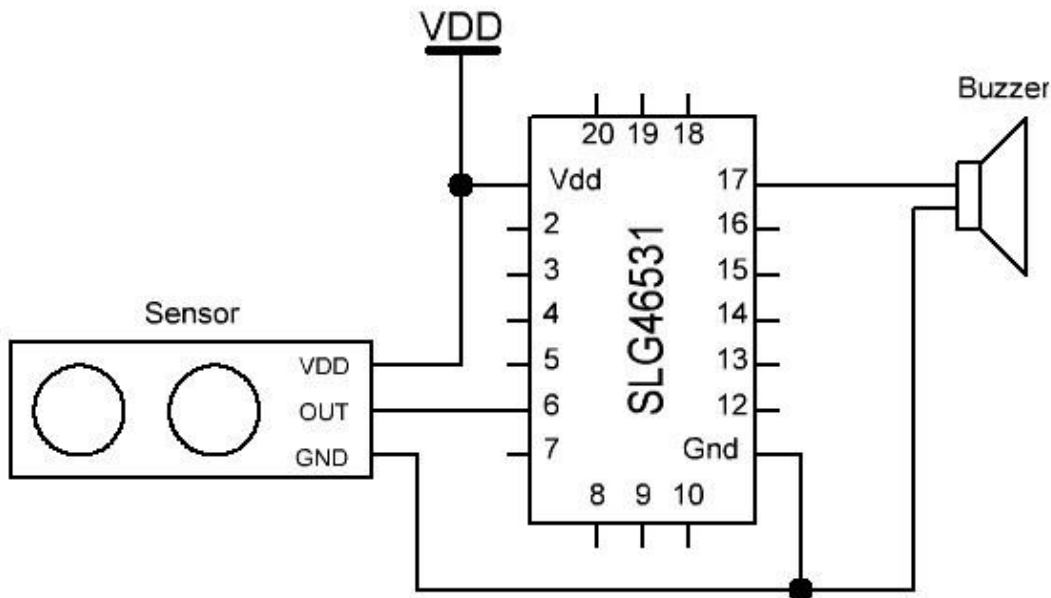

**Figure 8. General schematic**

### Schematic

The whole system consists of the GreenPAK, the GP2Y0A60SZLF proximity sensor and a 5 Volt Buzzer. Figure 8 shows how the circuit needs to be connected.

### Conclusion

This App note explores the capabilities of the GreenPAK in the automotive industry. Using a simple and reliable design, this system can be implemented in newer models as well as in a standalone system that can be integrated into older models.

The differences in the voltage readings between different materials are small, which enable us to generalize the values without having to worry about the material of the object in proximity to the automobile.

The core design presented in this app note can be modified to fit different requirements without much trouble, and it would still be reliable with most materials.

This design did not consume all of the internal resources of the GreenPAK chip, so the user can add additional functionality to this design if desired.



## **About the Author**

Name: Onésimo Ivan Fernandez

Background: Mechatronic engineer graduated from UDLAP. He is currently pursuing a Master's degree in the field of Electronics and Computer Science. Focused on electronics and programming, Ivan developed and improved several projects during his senior year in college. He also participated and became the 2016 finalist in the INF Challenge in Mexico.

Contact: [\*\*appnotes@silego.com\*\*](mailto:appnotes@silego.com)



## Document History

Document Title: Parking Assist System with GreenPAK

Document Number: AN-1154

Revision	Orig. of Change	Submission Date	Description of Change
A	Onésimo Ivan Fernandez	02/17/2017	New application note

## Worldwide Sales and Design Support

Silego Technology maintains a worldwide network of offices, solution centers, manufacturer's representatives, and distributors. To find the sales person closest to you, visit us at **Sales Representatives and Distributors**.

## About Silego Technology

Silego Technology, Inc. is a fabless semiconductor company headquartered in Santa Clara, California, with operations in Taiwan, and additional design/technology centers in China, Korea and Ukraine.



**SILEGO**  
TECHNOLOGY

**Silego Technology Inc.**  
1515 Wyatt Drive  
Santa Clara, CA 95054

**Phone:** 408-327-8800  
**Fax:** 408-988-3800  
**Website:** [www.silego.com](http://www.silego.com)